

CONE CRUSHER

Exceptional Portability | Simplified Operation | Superior Compatability

TRACK MOUNTED CRUSHING PLANT



AGGREGATE AND
MINING GROUP

The FT300 provides maximum cone crushing performance on a versatile track-mounted carrier. The FT300 features the quarry proven Kodiak 300+ cone crusher, which delivers crushing volumes of up to 460 TPH. The FT300's feed conveyor is adjustable to multiple positions and the under-crusher discharge conveyor can be installed to discharge out either end of the plant, making the FT300 a very versatile open or closed-circuit crushing system.

CONE CRUSHER

MODEL FT300

36"

Variable speed belt feeder, heavy duty grade 1 belting.

325 H.P / 425 H.P.

CAT engine, provides power for crusher and on-board conveyors.

8'9 3/4" x 45' 7"

Operating Footprint

Up to 460 TPH

460 TPH with the GT300

PERFORMANCE

- P1 Low Profile**
Designed to simply drive off transport and begin crushing.
- P2 Compact Design**
System transports on standard lowboy making them easy to transport.

EASE-OF-USE

- E1 Minimal Site Prep**
Spend time unloading and stockpiling instead.
- E2 On-Site Portable**
These plants quickly relocate at the job site.

DURABILITY

- D1 Heavy Duty Tracks**
Extremely durable and mobile.

SAFETY

- S1 Minimize Exposure**
Once positioned, the operator can feed the plant from the safety of the loading device.

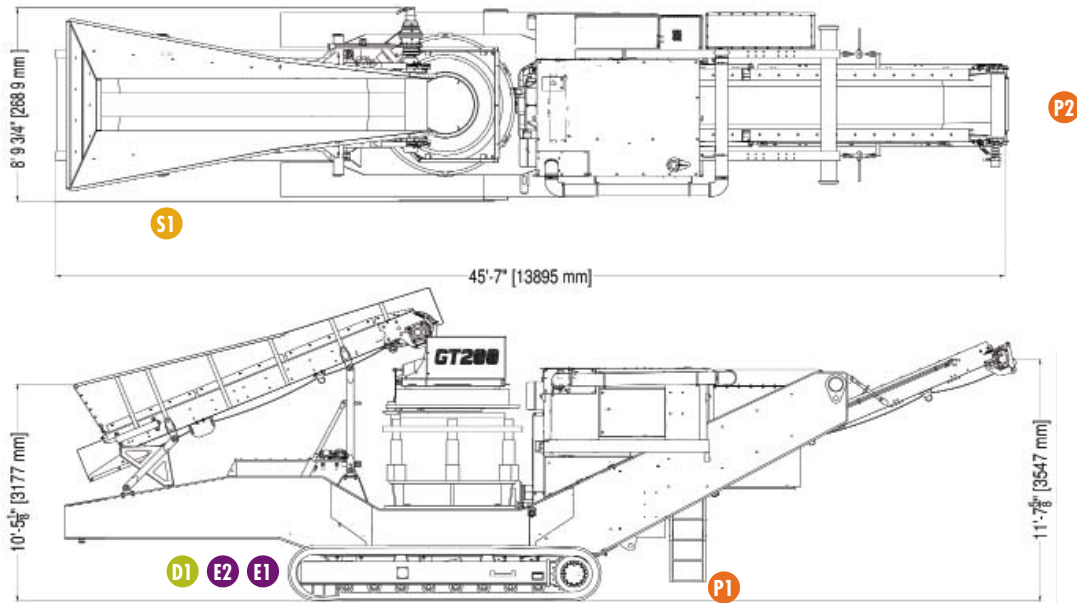

QUARRY DUTY CONE CRUSHER

The robust Kodiak Plus cone crusher features hydraulic adjustment and an aggressive crushing chamber.



ADJUSTABLE FEED CONVEYOR

Multiple positions for open/closed-circuit configurations and a pivoting head section for easy liner replacement.



REVERSIBLE DISCHARGE CONVEYOR

The discharge conveyor can be installed to discharge to either end for maximum system versatility.

www.kpijci.com

PART OF THE FAST TRACK SYSTEM®

Combine with the GT125 Jaw Crusher and the GT145S Screen for a portable crushing and screening system.

SERVICE MADE EASY

Because we're dedicated to keeping you up and running, we've provided two resources for quality O.E.M. parts and 24/7 service. KPI-JCI and Astec Mobile Screens parts and service are available from your local dealer and/or representative.

Find the dealer or representative nearest you at www.kpijci.com.

Because KPI-JCI & Astec Mobile Screens may use in their catalog & literature, old photographs of its products which may have been modified by the owners, products furnished by KPI-JCI & Astec Mobile Screens may not necessarily be as illustrated therein. Also continuous design progress makes it necessary that specifications be subject to change without notice. All sales of the products of KPI-JCI & Astec Mobile Screens are subject to the provisions of its standard warranty. KPI-JCI & Astec Mobile Screens do not warrant or represent that their products meet any federal, state, or local statutes, codes, ordinances, rules, standards or other regulations, including OSHA and MSHAGATOR, covering safety pollution, electrical, wiring, etc. Compliance with these statutes and regulations is the responsibility of the user and will be dependent upon the area and the use to which the product is put by the user. In some photographs, guards may have been removed for illustrative purposes only. This equipment should not be operated without all guards attached in their normal position. Placement of guards and other safety equipment is often dependent upon the area and the use to which the product is put. A safety study should be made by the user of the application, and, if required, additional guards, warning signs and other safety devices should be installed by the user, wherever appropriate before operating the products.

NOTE: SPECIFICATIONS ARE SUBJECT TO CHANGE WITHOUT NOTICE

Rev 1_1010_IH