

FOLD 'N GO[®]

Self Contained Track Plant | Superior Toughness | Unmatched Screen Capacity

TRACK SCREENING PLANT



AGGREGATE AND
MINING GROUP

All FAST TRAX screening plants feature the ultimate in screen production and efficiency. All FT track screening plants are designed for operation with track crushers in tight spots and comes with a triple deck, 6'X20' top deck and middle deck and a 6'X18' bottom deck for a wide range of applications from crushed stone to RAP. As with all track screening plants offered by Astec Mobile Screens, the FT3620 Fold 'n Go with Feed Bin offers totally self contained diesel power with standard wireless remote for plant movement. This track screening plant provides the highest screen capacity in the market for material separation ranging from 4" to 1/8" depending on the application, with maximum feed size of 8".

FT3620 FOLD 'N GO W BIN

4" to 1/8"

Standard material separations range from 4" to 1/8" depending on application.

140 HP

Tier III John Deere water cooled diesel engine to power all plant functions.

850 or 1150 RPM

Up to 850 RPM at 3/8" stroke and 1150 RPM at 3/16" stroke

Up to 700 TPH

Screening plant can process up to 700TPH or more of 8" feed material

PERFORMANCE

- P1 3620 Triple Deck Screen**
Triple deck: 6' X 20' top deck and middle deck and 6' X 18' bottom deck for improved screen production.

PORTABILITY

- D1 Track System**
Wireless control for ease of movement on the job site. Fits on lowboy for convenient transport from site to site.

SAFETY

- S1 Dust Cover**
The vinyl dust cover provides dust control and cleaner air in the work area.

EASE-OF-USE

- E1 Fast Setup**
Quick setup times give producers more time to produce material.
- E2 Central Grease Points**
Makes routine services easy.

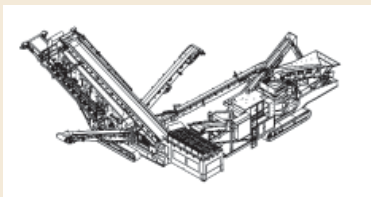
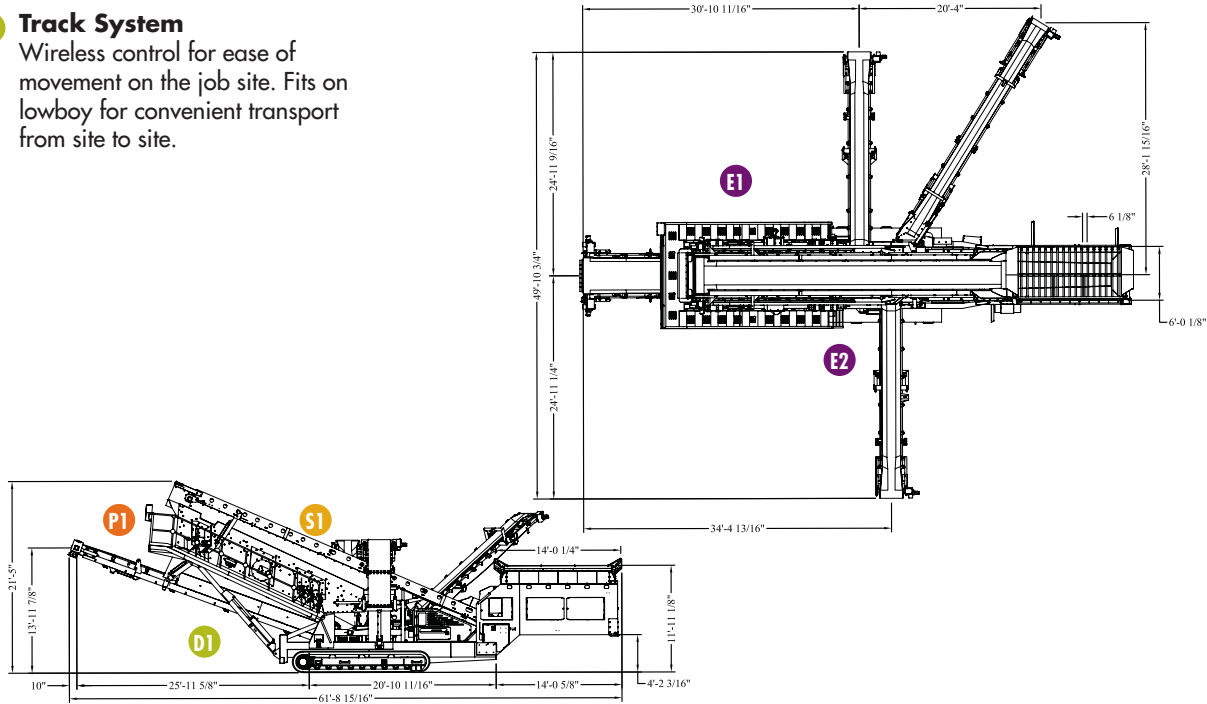

Made to Match

The FT3620 FNG matches with other FT products from KPI-JCI without the use of off plant stackers to create a complete mobile production system.



Hopper

Feed hopper has a capacity of 10 cubic yards and a 14' opening



Superior Separation

The 6 X 20 is an industry leader for the incline screen market, especially in the 4" to 1/8" range in a wide range of applications, from crushed stone to RAP.

www.kpijci.com

PART OF THE FAST TRAX FAMILY OF EQUIPMENT.

Designed to run with the KPI-JCI family of tracked impactors to produce high capacities of saleable products.

SERVICE MADE EASY

Because we're dedicated to keeping you up and running, we've provided two resources for quality O.E.M. parts and 24/7 service. Astec Mobile Screens and KPI-JCI parts and service are available from you local dealer and/or representative.

Find the dealer or representative nearest you at www.kpijci.com.

Because Astec Mobile Screens may use in its catalog & literature, field photographs of its products which may have been modified by the owners, products furnished by Astec Mobile Screens may not necessarily be as illustrated therein. Also continuous design progress makes it necessary that specifications be subject to change without notice. All sales of the products of Astec Mobile Screens are subject to the provisions of its standard warranty. Astec Mobile Screens does not warrant or represent that its products meet any federal, state, or local statutes, codes, ordinances, rules, standards or other regulations, including OSHA and MSHAGATOR, covering safety pollution, electrical, wiring, etc. Compliance with these statutes and regulations is the responsibility of the user and will be dependent upon the area and the use to which the product is put by the user. In some photographs, guards may have been removed for illustrative purposes only. This equipment should not be operated without all guards attached in their normal position. Placement of guards and other safety equipment is often dependent upon the area and the use to which the product is put. A safety study should be made by the user of the application, and, if required, additional guards, warning signs and other safety devices should be installed by the user, wherever appropriate before operating the products.

NOTE: SPECIFICATIONS ARE SUBJECT TO CHANGE WITHOUT NOTICE

REV. 3/9/2011