

# JAW CRUSHER

## Model 2640 Spec Sheet

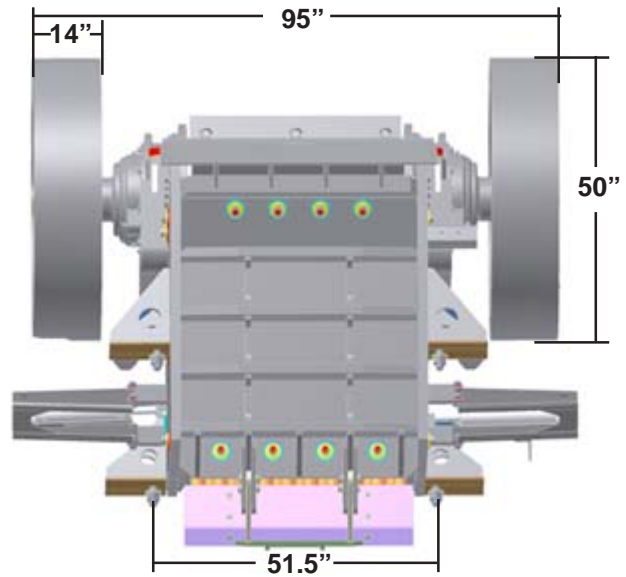
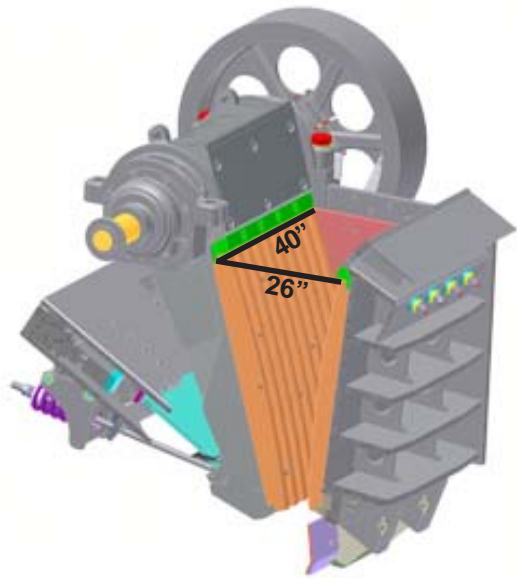

### ● SHAFT

- SAE4140 forged steel shaft
- Increased stroke

### ● BEARINGS

- Spherical roller self-aligning type with straight bore pitman bearing
- Tapered bore main bearing
- Pillow block housing mounted in saddle blocks

### ● FLYWHEEL

- Ductile iron 50" diameter
- Grooveless flywheel

### ● PITMAN

- Cast steel design

### ● BASE

- Low carbon steel fabrication
- Stress relieved

### ● TOGGLE

- Ductile iron
- Steep angle for increased production

### ● SIDE LINERS

- Abrasion resistant steel
- (3) three piece bolt on

### ● JAW DIES

- Manganese steel with machined back
- Multiple configurations available

### ● ADJUSTMENT

- Hydraulic dual wedge

### ● LUBRICATION

- Grease system

● **CRUSHER DATA**

Jaw Opening (Gap).....26" (660mm)  
 Jaw Width.....40" (1016mm)  
 Moving Jaw, Overall Depth.....53" (1346mm)  
 Stationary Jaw, Overall Depth.....49" (1244mm)

Weight.....29,500 lb (13,393 kg)  
 Power Required (HP).....125 Electric, 160 Diesel  
 RPM.....285 Maximum  
 Stroke.....1-1/4"

APPROXIMATE GRADATIONS AT PEAK TO PEAK CLOSED SIDE SETTINGS														
Test Sieve Sizes (in.)	3/4"	1"	1 1/4"	1 1/2"	2"	2 1/2"	3"	3 1/2"	4"	5"	6"	7"	8"	Test Sieve Sizes (mm)
	19 mm	25.4 mm	31.8 mm	38.1 mm	50.8 mm	63.5 mm	76.2 mm	89.1 mm	102 mm	127 mm	152 mm	178 mm	203 mm	
12											100	98	95	305
10										100	97	95	90	254
8									100	96	92	85	75	203
7	Values are percent passing							100	97	92	85	76	65	178
6							100	98	93	85	74	65	53	152
5						100	97	95	85	73	62	52	40	127
4					100	96	90	85	70	56	45	38	28	102
3				100	93	85	75	65	50	38	32	27	23	76.2
2 1/2			100	95	85	73	62	52	38	31	24	22	17	63.5
2		100	96	85	70	55	47	39	28	24	20	17	13	50.8
1 1/2	100	93	85	67	49	39	33	27	21	18	15	13	10	38.1
1 1/4	96	85	73	55	39	31	27	23	17	15	13	10	8	31.8
1	85	69	55	40	29	24	20	17	14	12	10	8	6	25.4
3/4	66	49	39	28	21	18	15	13	11	9	8	6	5	19
1/2	41	29	24	19	14	12	10	9	7	6	6	5	4	12.7
3/8	28	21	18	14	11	9	8	7	5	5	5	4	3	9.53
1/4	18	14	12	10	7	7	6	5	4	4	4	3	2	6.35
#4	12	10	9	7	5	5	4	4	3	3	3	2	1	#4
#8	6	6	5	5	4	4	3	3	2	2	2	1	0.5	#8

Peak to Peak Closed Side Setting - Approximate Capacity						
Crusher Setting	inches	2 1/2"	3"	3 1/2"	4"	5"
	mm	64	76	89	102	127
* Tons per Hour	mt/h	140	160	180	200	240
		128	145	164	182	218

\* Based on material weighing 2700 lb per cubic yard  
 Capacity may vary as much as ±25%

**NOTE:** Specifications are subject to change without notice.

Because KPI-JCI may use in its catalog & literature, field photographs of its products which may have been modified by the owners, products furnished by KPI-JCI may not necessarily be as illustrated therein. Also continuous design progress makes it necessary that specifications be subject to change without notice. All sales of the products of KPI-JCI are subject to the provisions of its standard warranty. KPI-JCI does not warrant or represent that its products meet any federal, state, or local statutes, codes, ordinances, rules, standards or other regulations, including OSHA and MSHA, covering safety, pollution, electrical wiring, etc. Compliance with these statutes and regulations is the responsibility of the user and will be dependent upon the area and the use to which the product is put by the user. In some photographs, guards may have been removed for illustrative purposes only. This equipment should not be operated without all guards attached in their normal position. Placement of guards and other safety equipment is often dependent upon the area and how the product is used. A safety study should be made by the user of the application, and, if required additional guards, warning signs and other safety devices should be installed by the user, wherever appropriate before operating the products.