



3055 PRIMARY JAW PLANT



PLANT FEATURES	
PLANT CONFIGURATION	Diesel / Hydraulic
AXLE CONFIGURATION	Equalized Triple Axle w/ Triple Stinger
TIRES	(24) 11:00 x 22.5 Dual Mounted w/ Air Brakes
BULKHEAD	Hydraulic Raise and Lower - Both Sides
DIESEL ENGINE	Caterpillar C13 415 HP w/ Trans-fluid Hydraulic Clutch
FUEL TANK	Dual 180 Gallon
DELIVERY CONVEYOR	48 in. Wide - Hydraulically Driven w/ Impact Bed
DISCHARGE HEIGHT	16 ft.
BELTING	(3) Ply, 330 PIW, 1/4 in. Top, 1/8 in. Bottom, Grade 1 Rubber
GROUND SUPPORTS	Hydraulic w/ Pontoon Bases
PLATFORMS	Operator and Diesel Observation
DUST SUPPRESSION	Complete w/ Manifold, Filtration, and On-Plant Shutoff

JAW FEATURES	
SIZE	30 in. x 55 in Vanguard
BASE	Welded Fabrication
TYPE	Overhead Eccentric
BEARINGS	Spherical Self-Aligning Roller
LUBRICATION	Grease
ADJUSTMENT	Hydraulic Dual Wedge
DRIVE FLYWHEEL	63 in. Diameter - 10-SV Drive / 50 in. flat
SIDE LINERS	Bolted - 3 Piece
JAW DIE RETENTION	Bolted
JAW DIES	Reversible Manganese
JAW TOE	Replaceable Retention Tip
JAW DIE LENGTH	Stationary - 59.5 in Moveable - 60.5 in.
STROKE	1 1/2 in.

CAPACITIES	
50 IN. FEEDER	650 rpm = 623 tph 700 rpm = 671 tph 750 rpm = 720 tph 800 rpm = 767 tph
GRIZZLY FEEDER	At 3.5 in. nom. = 328-437 tph At 4 in. nom. = 375-500 tph At 4.5 in. nom. = 422-562 tph At 5 in. nom. = 468-625 tph At 5.5 in. nom. = 515-687 tph At 6 in. nom. = 562-750 tph
JAW CRUSHER	At 3 in. css = 265 tph At 3.5 in. css = 300 tph At 4 in. css = 334 tph At 5 in. css = 402 tph At 6 in. css = 471 tph At 7 in. css = 528 tph

*Capacities based on material weighing 2,700 lbs./ cu. ft.

FEEDER SPECS
50 in. x 20 ft. Horizontal vibrating grizzly feeder
6 ft. long adjustable tapered grizzly bars
14 ft. long heavy duty pan section
1 in. thick deck plate
3/4 in. thick AR steel pan liners
Heavy duty spring suspension
110mm feeder bearings



3055 PRIMARY JAW PLANT

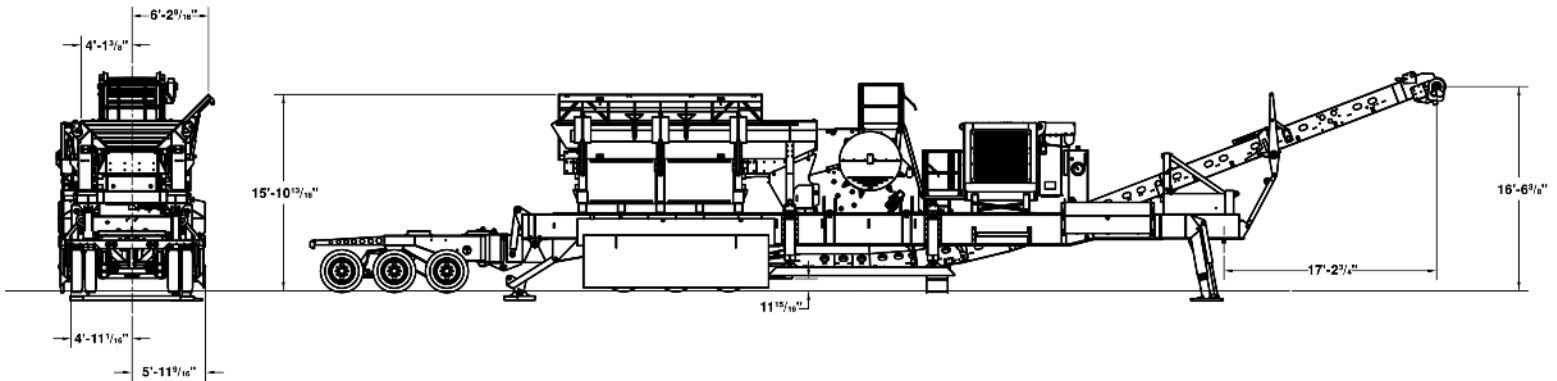

GRADATION - OPEN CIRCUIT															
Test Sieve Sizes (in.)	APPROXIMATE GRADATIONS AT PEAK TO PEAK CLOSED SIDE SETTINGS												Test Sieve Sizes (in.)		
	3/4"	1"	1 1/4"	1 1/2"	2"	2 1/2"	3"	3 1/2"	4"	5"	6"	7"		8"	
	19 mm	25.4 mm	31.8 mm	38.1 mm	50.8 mm	63.5 mm	76.2 mm	89.1 mm	102 mm	127 mm	152 mm	178 mm	203 mm		
12"												100	98	95	305
10"										100	97	95	90	254	
8"									100	96	92	85	75	203	
7"	Values Are Percent Passing								100	97	92	85	76	65	178
6"							100	98	93	85	74	65	53	152	
5"						100	97	95	85	73	62	52	40	127	
4"					100	96	90	85	70	56	45	38	28	102	
3"				100	93	85	75	65	50	38	32	27	23	76.2	
2 1/2"			100	95	85	73	62	52	38	31	24	22	17	63.5	
2"	100	96	85	70	55	47	39	28	24	20	17	13	13	50.8	
1 1/2"	100	93	85	67	49	39	33	27	21	18	15	13	10	38.1	
1 1/4"	96	85	73	55	39	31	27	23	17	15	13	10	8	31.8	
1"	85	69	55	40	29	24	20	17	14	12	10	8	6	25.4	
3/4"	66	49	39	28	21	18	15	13	11	9	8	6	5	19.0	
1/2"	41	29	24	19	14	12	10	9	7	6	6	5	4	12.7	
3/8"	28	21	18	14	11	9	8	7	5	5	5	4	3	9.53	
1/4"	18	14	12	10	7	7	6	5	4	4	4	3	2	6.35	
#4	12	10	9	7	5	5	4	4	3	3	3	2	1	#4	
#8	6	6	5	5	4	4	3	3	2	2	2	1	0.5	#8	

WEIGHTS AND DIMENSIONS	
AXLE SPACING	51 in.
KINGPIN	72,060 lbs.
REAR AXLE EACH	17,600 lbs.
REAR AXLE TOTAL	52,800 lbs.
TAG	53,600 lbs.
TOTAL WEIGHT	178,540 lbs.
TRAVEL HEIGHT	13 ft. - 11 in.
TRAVEL LENGTH	80 ft. - 2 in.
TRAVEL WIDTH	11 ft. - 11 in.

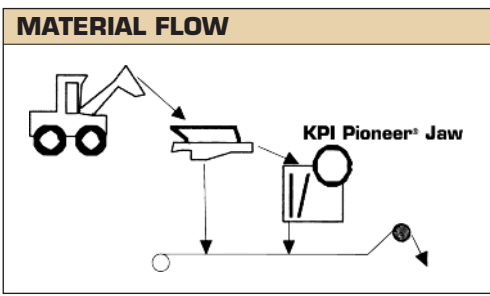

NOTE: SPECIFICATIONS ARE SUBJECT TO CHANGE WITHOUT NOTICE

Because KPI-JCI, AMS and BTI may use in their catalogs & literature, field photographs of it's products which may have been modified by the owners, products furnished by KPI-JCI, AMS and BTI may not necessarily be as illustrated therein. Also continuous design progress makes it necessary that specifications be subject to change without notice. All sales of the products of KPI-JCI, AMS and BTI are subject to the provisions of it's standard warranty. KPI-JCI, AMS and BTI does not warrant or represent that their products meet any federal, state, or local statutes, codes, ordinances, rules, standards or other regulations, including OSHA and MSHA, covering safety, pollution, electrical wiring, etc. Compliance with these statutes and regulations is the responsibility of the user and will be dependent upon the area and the use to which the product is subjected by the user. In some photographs, guards may have been removed for illustrative purposes only. This equipment should not be operated without all guards attached in their normal position. Placement of guards and other safety equipment is often dependent upon the area and how the product is used. A safety study should be made by the user of the application and, if required additional guards, warning signs and other safety devices should be installed by the user, wherever appropriate before operating the products.



1-800-542-9311