



## PLANT FEATURES

<b>PLANT CONFIGURATION</b>	Diesel / Electric
<b>AXLE CONFIGURATION</b>	2 + 3 air bag suspension, hydraulically retractable
<b>TIRES</b>	(20) 11:00 x 22.5 dual mounted w/air brakes
<b>UNDERSCREEN CONVEYORS</b>	(2) 30" wide side by side reversing w/5 hp electric motors each
<b>U/S CONVEYORS</b>	Hyd. articulate for infinite blending to side discharge conveyors
<b>OVERS FRONT DELIVERY CONVEYOR</b>	42" wide with 15 hp electric motor
<b>"FRONT" SIDE DELIVERY CONVEYOR</b>	30" wide with 7½ hp electric motor
<b>DISCHARGE HEIGHT</b>	7' - 2"
<b>"CENTER" SIDE DELIVERY CONVEYOR</b>	30" wide with 7½ hp electric motor
<b>DISCHARGE HEIGHT</b>	7' - 2"
<b>"REAR" SIDE DELIVERY CONVEYOR</b>	30" wide with 7½ hp electric motor
<b>DISCHARGE HEIGHT</b>	7' - 2"
<b>TRANSFER CONVEYOR</b>	42" wide with 7½ hp electric motor
<b>ALL BELTING</b>	Grade 2, 3 ply, ¾" top, ½" bottom, Grade 1 rubber
<b>BELT CLEANER</b>	Martin ClearChoice
<b>DIESEL ENGINE</b>	Caterpillar C-13 440 hp w/300 kw genset
<b>DIESEL BAGHOUSE</b>	Pulse cleaning air-intake
<b>FUEL TANK</b>	500 gallons
<b>GROUND SUPPORTS</b>	Hydraulic with oversized bases
<b>PLATFORMS</b>	Complete around (4) sides of screen
<b>DUST SUPPRESSION</b>	Complete with manifold, filtration, and on-plant shutoff

## SCREEN FEATURES

Heavy-duty huck-bolted assembly
50 hp electric motor
¼" side plate thickness
190W mm bearings
Adjustable stroke length, stroke angle, and operating speed
Length - ⅝" and ¾"
Angle - 30 - 60 degrees
Speed - 675 - 875 rpm
Quickly adjusts to fit fine or coarse screening
Fully contained oil lubrication system
24" feedbox
¼" feed box liners (AR plate)
Maximum feed size is 10"
Maximum top deck opening 4"
Maximum drop of feed 18"
¼" discharge lip liner thickness (AR plate)
No welded-on sidehill washers
Utilizes keyless hub to shaft locking assembly system
Superior load carrying double-roll bronze cage spherical bearings
Slip-on gear design
Rubber springs to reduce basket stress



# 8203 FINISHING SCREEN

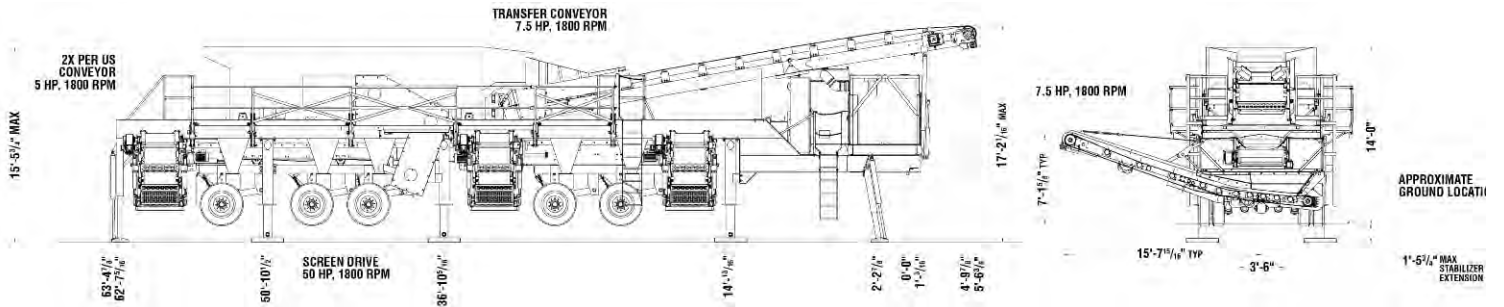

WEIGHTS AND DIMENSIONS	
AXLE SPACING	54\"/>
KINGPIN	15,400
STEER	36,600
STEER SPACING	63\"/>
REAR AXLE EACH	19,960
REAR AXLE TOTAL	59,880
TOTAL WEIGHT	111,880
TRAVEL HEIGHT	14'-0\"/>
TRAVEL LENGTH	69'-2\"/>
TRAVEL WIDTH	12'-0\"/>

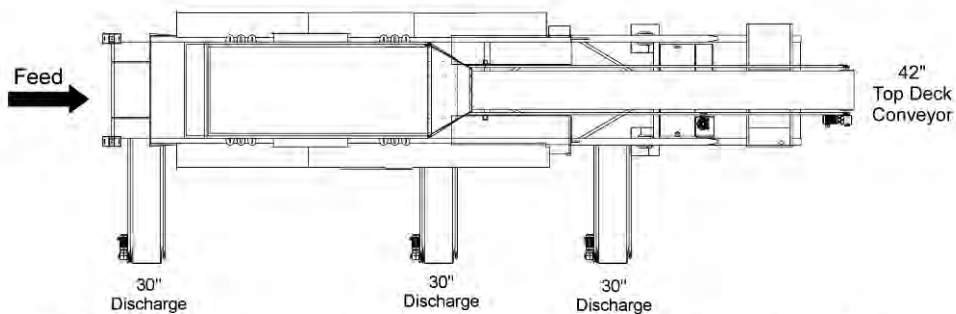
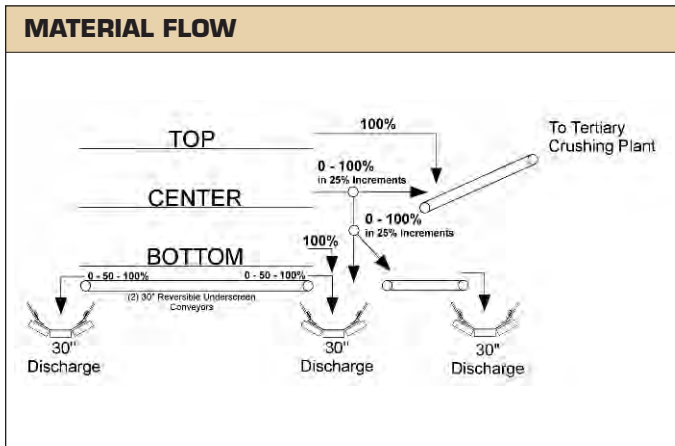

NOTE: All (3) discharge conveyors can be installed to discharge out either side of the plant and are field reversible

NOTE: SPECIFICATIONS ARE SUBJECT TO CHANGE WITHOUT NOTICE

KPI/JCI 3.5 PG 2/09

Because KPI-JCI, AMS and BTI may use in their catalogs & literature, field photographs of it's products which may have been modified by the owners, products furnished by KPI-JCI, AMS and BTI may not necessarily be as illustrated therein. Also continuous design progress makes it necessary that specifications be subject to change without notice. All sales of the products of KPI-JCI, AMS and BTI are subject to the provisions of it's standard warranty. KPI-JCI, AMS and BTI does not warrant or represent that their products meet any federal, state, or local statutes, codes, ordinances, rules, standards or other regulations, including OSHA and MSHA, covering safety, pollution, electrical wiring, etc. Compliance with these statutes and regulations is the responsibility of the user and will be dependent upon the area and the use to which the product is subjected by the user. In some photographs, guards may have been removed for illustrative purposes only. This equipment should not be operated without all guards attached in their normal position. Placement of guards and other safety equipment is often dependent upon the area and how the product is used. A safety study should be made by the user of the application and, if required additional guards, warning signs and other safety devices should be installed by the user, wherever appropriate before operating the products.



1-800-542-9311



ASTE  
NASDAQ  
LISTED

Astec Industries Companies