



PSP 2618VM HIGH FREQUENCY SCREEN



PLANT FEATURES

PLANT CONFIGURATION	Diesel / Hydraulic
AXLE CONFIGURATION	Triple Axle w/ Spring Suspension
TIRES	(12) 11:00 x 22.5 Dual Mounted w/ Air Brakes
GROUND SUPPORTS	Hydraulic with oversized bases
FEEDER HOPPER	8' x 14', 12 cubic yard capacity
ROLLER BELT FEEDER	12' long x 32" wide w/ hydraulic variable speed
BELT FEEDER BELTING	2-ply 3/16" x 1/16" fastened w/ mechanical fasteners
FEED CONVEYOR	36" wide hydraulically driven
SIDE DISCHARGE CONVEYORS	(2) 24" wide hydraulically driven
FINES DISCHARGE CONVEYOR	36" wide hydraulically driven
DISCHARGE CONVEYOR BELTING	2-ply 1/8" x 1/16" fastened w/ mechanical fasteners
BELT CLEANER	Martin ClearChoice
DIESEL ENGINE	Caterpillar rated at 300 hp w/ 125 kw Genset
DIESEL BAGHOUSE	Pulse cleaning air-intake
FUEL TANK	GET FROM AMS
DUST SUPPRESSION	Complete with manifold, filtration, and on-plant shutoff

SCREEN FEATURES

- Modified 6' x 18' double deck
- Directly induced variable high frequency screen
- Heavy-duty 3/8" thick screen box sides
- Eleven variable speed hydraulic vibrators
- Five force amplitude settings on adjustable slip counter weights
- Hinged aggregate spreader
- 6' x 18' collecting hopper
- Discharge chutes and covers
- Hydraulic screen angle adjustments
- Removable 22 oz. black vinyl dust cover

CAPACITIES

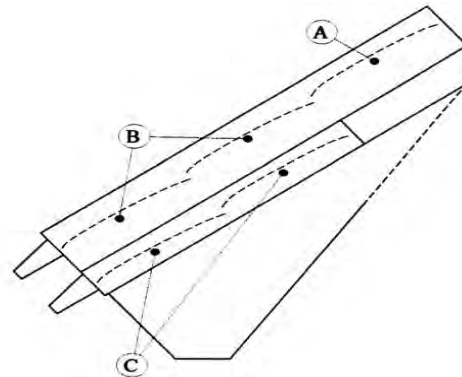

Through Deck, Slotted Screen	B/C, TPH sq. ft.	Pre Screen Deck SECTION A TPH, 36 sq. ft.	Chip Deck SECTION B TPH, 72 sq. ft.	Post Screen Fine Deck SECTION C TPH, 72 sq. ft.
3/4"	4.60	165.6 TPH	301.5 TPH	265.0 TPH
5/8"	4.20	151.2 TPH	274.5 TPH	241.9 TPH
1/2"	3.81	137.1 TPH	247.5 TPH	219.5 TPH
3/8"	3.33	119.9 TPH	216.0 TPH	191.8 TPH
1/4"	2.91	104.8 TPH	189.0 TPH	167.6 TPH
3/16" (4M)	2.43	87.5 TPH	157.5 TPH	140.0 TPH
1/8" (6M)	1.60	57.6 TPH	103.5 TPH	92.2 TPH
3/32" (8M)	1.18	42.5 TPH	76.5 TPH	68.0 TPH
1/16" (10M)	0.90	32.4 TPH	58.5 TPH	51.8 TPH
1/16" (12M)	0.70	25.2 TPH	45.0 TPH	40.3 TPH
3/64" (16M)	0.55	19.8 TPH	36.0 TPH	31.7 TPH
1/32" (20M)	0.43	15.5 TPH	27.9 TPH	24.8 TPH
3/256" (30M)	0.33	11.9 TPH	21.4 TPH	19.0 TPH
1/64" (40M)	0.22	7.92 TPH	14.3 TPH	12.7 TPH



PSP 2618VM HIGH FREQUENCY SCREEN

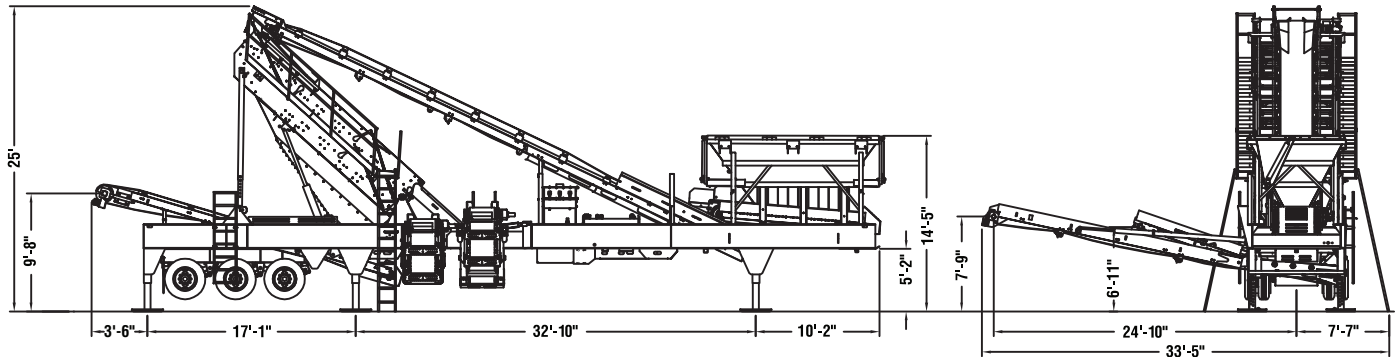

WEIGHTS AND DIMENSIONS	
AXLE SPACING	48 in. & 50 in.
KINGPIN	26,000 lbs.
REAR AXLE EACH	15,330 lbs.
REAR AXLE TOTAL	45,990 lbs.
TOTAL WEIGHT	71,990 lbs.
TRAVEL HEIGHT	13 ft. - 6 in.
TRAVEL LENGTH	65 ft. - 0 in.
TRAVEL WIDTH	10 ft. - 11 in.

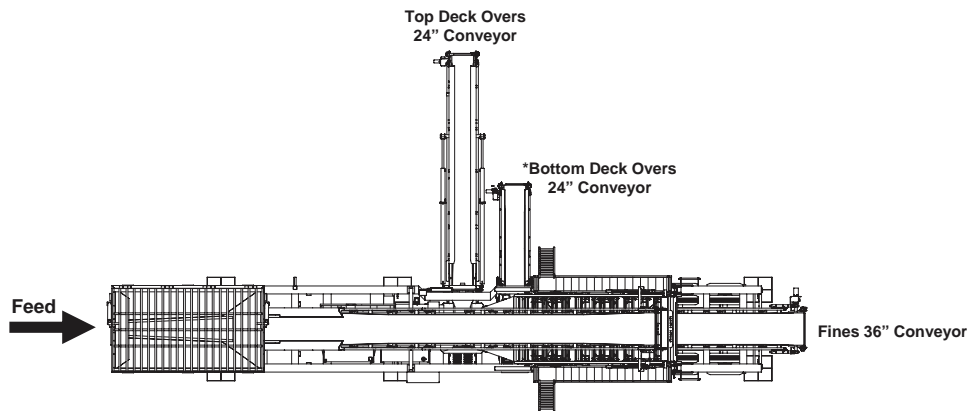
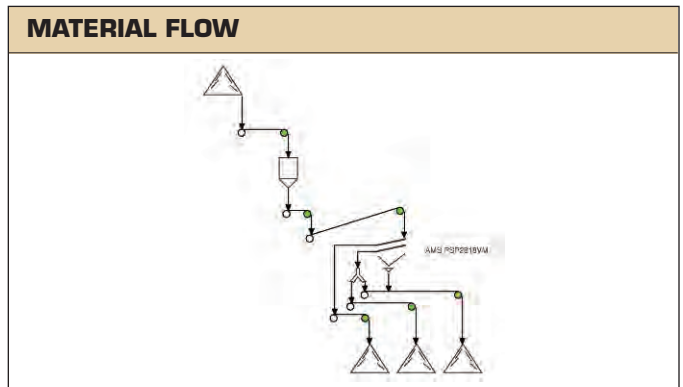

Both top deck and bottom deck overs conveyors can be mounted to discharge on either side of screen plant.

NOTE: SPECIFICATIONS ARE SUBJECT TO CHANGE WITHOUT NOTICE

KPI/JCI 3.5 PG 02/09

Because KPI-JCI, AMS and BTI may use in their catalogs & literature, field photographs of it's products which may have been modified by the owners, products furnished by KPI-JCI, AMS and BTI may not necessarily be as illustrated therein. Also continuous design progress makes it necessary that specifications be subject to change without notice. All sales of the products of KPI-JCI, AMS and BTI are subject to the provisions of it's standard warranty. KPI-JCI, AMS and BTI does not warrant or represent that their products meet any federal, state, or local statutes, codes, ordinances, rules, standards or other regulations, including OSHA and MSHA, covering safety, pollution, electrical wiring, etc. Compliance with these statutes and regulations is the responsibility of the user and will be dependent upon the area and the use to which the product is subjected by the user. In some photographs, guards may have been removed for illustrative purposes only. This equipment should not be operated without all guards attached in their normal position. Placement of guards and other safety equipment is often dependent upon the area and how the product is used. A safety study should be made by the user of the application and, if required additional guards, warning signs and other safety devices should be installed by the user, wherever appropriate before operating the products.



1-800-542-9311



ASTE
NASDAQ
LISTED

Astec Industries Companies