

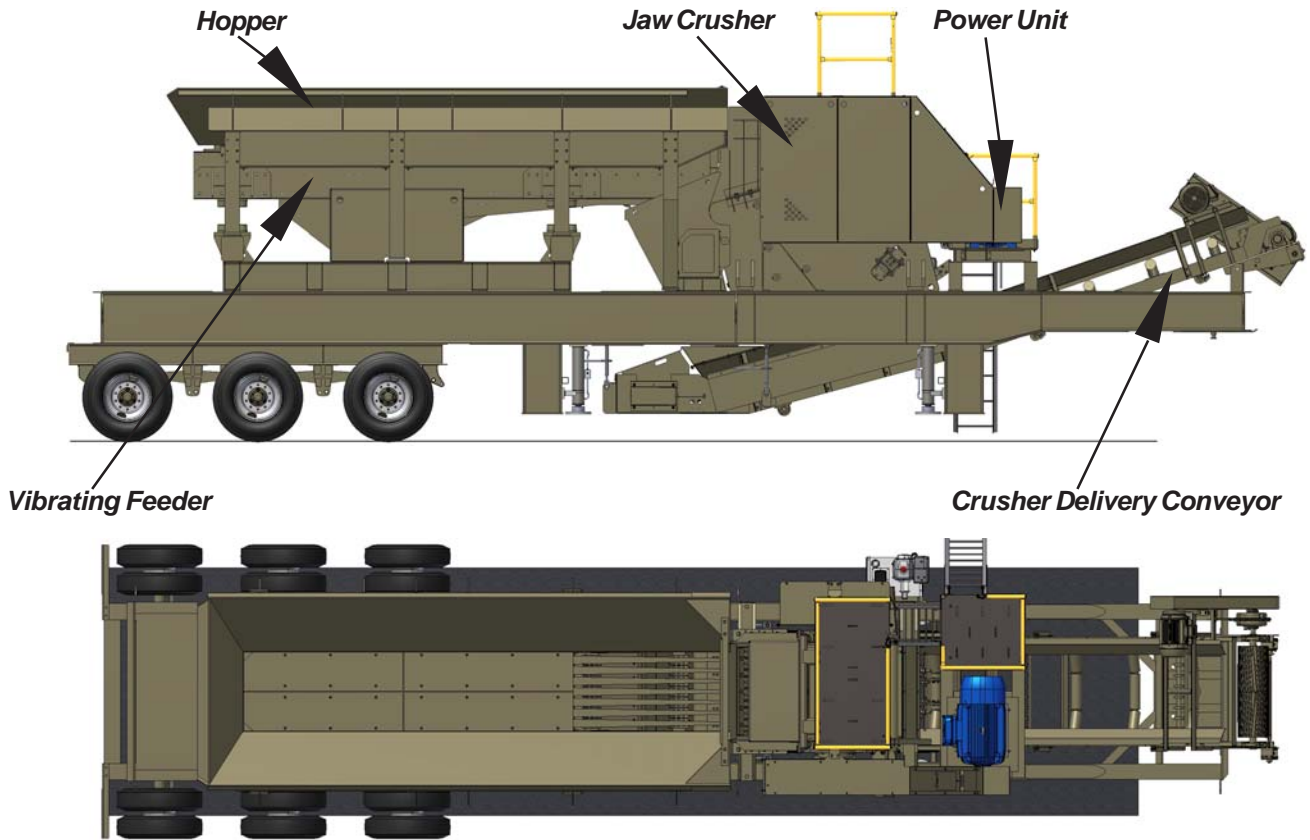

PORTABLE JAW PLANT Model RS3144 Spec Sheet



● RS3144 Portable Jaw Plant

- Designed to handle typical quarry rock or sand & gravel
- Utilizes a vibrating feeder and grizzly section
- All in one feed and scalping operation
- Low cost / Low maintenance crushing

● Main Plant Chassis

- I-beam frame
- Rear triple axle hutch suspension
- Hub piloted wheels bias tires 12-11:00 x 22.5
- Air brakes
- Fifth wheel plate and pin

● 3144 Jaw Crusher

- Grease lubrication
- Jaw mounted at 15°
- Drive 150 hp 1200 rpm (electric or diesel option)
- Large stroke of 1-1/2"

● 42" x 25' Crusher Delivery Conveyor

- V-belt drive 20 hp 1800 rpm electric motor
- Self-cleaning tail pulley
- 330-3 ply conveyor belt 350 fpm belt speed

● Hopper Feeder

- 42" wide x 20' long feeder
- 6' Adjustable and replacement grizzly
- 40 hp 1800 RPM motor

● Bypass Spout Under Feeder Grizzly

- Bypass uncrushed fines
- 1/4" AR 400 Liners

● OPTIONS

- Hydraulic Jack Raise
 - (4) 5" x 18" leveling jacks with 8 hp Honda power
- Front drop down legs tube in tube
- Hopper wing bracket
- Variable speed for the vibrating feeder
- Auto adjust

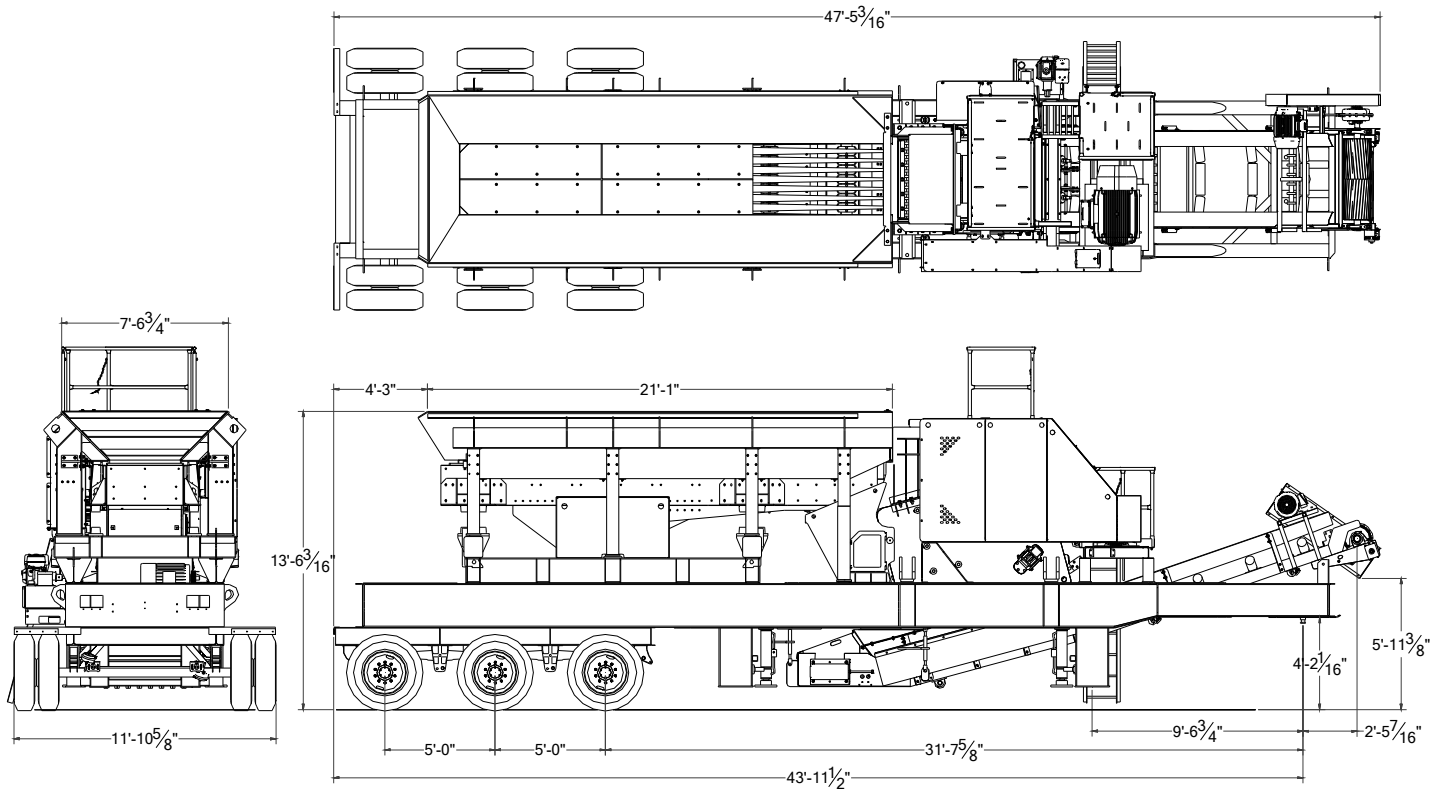

● **TRAVEL WEIGHT**

(includes motors, less optional conveyor)

Weight on the rear triple axle..... ≤59,000
 Total plant weight..... ≤102,000

Weight on the 5th wheel pin≤43,000

● **TRAVEL DIMENSIONS**

Overall length..... 48'
 Overall height..... 13' 6"
 Overall width..... 142"

Travel length, rear end to 5th wheel pin44'
 Minimum road clearance..... 12"
 5th wheel plate height..... 50"

● **OPERATING DIMENSIONS**

Feed height to top of feeder hopper.....13' 7"

Discharge height of under crusher conveyor..... 6'

● **PAINT**

one coat of primer, finish coat of Beige acrylic

NOTE: Specifications are subject to change without notice.

Because KPI-JCI may use in its catalog & literature, field photographs of its products which may have been modified by the owners, products furnished by KPI-JCI may not necessarily be as illustrated therein. Also continuous design progress makes it necessary that specifications be subject to change without notice. All sales of the products of KPI-JCI are subject to the provisions of its standard warranty. KPI-JCI does not warrant or represent that its products meet any federal, state, or local statutes, codes, ordinances, rules, standards or other regulations, including OSHA and MSHA, covering safety, pollution, electrical wiring, etc. Compliance with these statutes and regulations is the responsibility of the user and will be dependent upon the area and the use to which the product is put by the user. In some photographs, guards may have been removed for illustrative purposes only. This equipment should not be operated without all guards attached in their normal position. Placement of guards and other safety equipment is often dependent upon the area and how the product is used. A safety study should be made by the user of the application, and, if required additional guards, warning signs and other safety devices should be installed by the user, wherever appropriate before operating the products.



700 W 21st. St., Yankton, SD 57078
 1-800-542-9311 Fax: 605-665-8858

Email: mail@kpijci.com
 www.kpijci.com
 Mdl RS3144 7/11